

# Thermmax

a division of DVM Power + Control

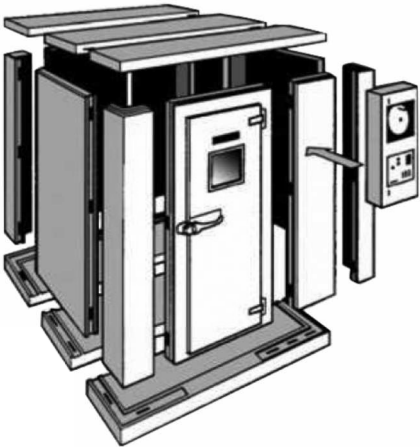

# Your Trusted Partner For Environmental Rooms

- Providing innovative solutions to meet your environmental room needs.
- Tailored services to support your business.



# Environmental Rooms That Exceed Your Standards

- Custom-designed rooms for temperature, humidity, and environmental control.
- Ideal for various industries: healthcare, research, chemical, and industrial applications including C1D1 classified structures.



# Precision Controlled Temperature and Humidity Chambers

- Scientific Research
- Pharmaceutical
- Life Science Applications
- Critical Product Storage and Testing
- C1D1 Classified Structures





## Standard Ranges

### Temperature

Cold Rooms: 2-10 °C

Warm Rooms: 20-50 °C

Stability Rooms: 15-40 °C

Freezers -20 °C

Environmental: 0-50 °C

Wide Range: -20-0 °C

Low Temperature: -40 °C

### Humidity

Standard: 20-90%RH

Dew Point: 4-50 °C

Desiccant Dryer Systems:  $\pm 2\%$ RH



## Standard Features

---

The Modular Environmental Rooms are constructed from a flexible system of foamed-in place Polyurethane panels. Surfaces are metal lined with various optional finishes. The panels are locked together with cam lock fasteners providing a tight vapor seal. The resulting insulation has a high energy efficient R value greater than 30 and provides a natural 100% closed cell moisture vapor barrier.

All Refrigeration is proportionally modulated for energy efficiency and non-CFC's reliability. All Refrigerants used are environmentally friendly non-CFC's.

RS485 interface for computer communication is available.

Temperatures are measured with RTD platinum sensors with NBS traceable accuracy. Humidity is measured with a precision linear sensor by Vaisala.

# In-House Engineering Team

---

- Expert engineers ready to discuss your needs and answer technical questions.
- Custom solutions designed specifically for your requirements.
- In-house expertise to ensure the best possible outcome for your project.



# Why Choose Thermmax?

- **Reliable:** Proven track record of delivering high-quality solutions.
- **Supportive:** Full support from design to completion.
- **Efficient:** Short lead times and tailored solutions.
- **Expertise:** In-house engineering for personalized service and innovative solutions.

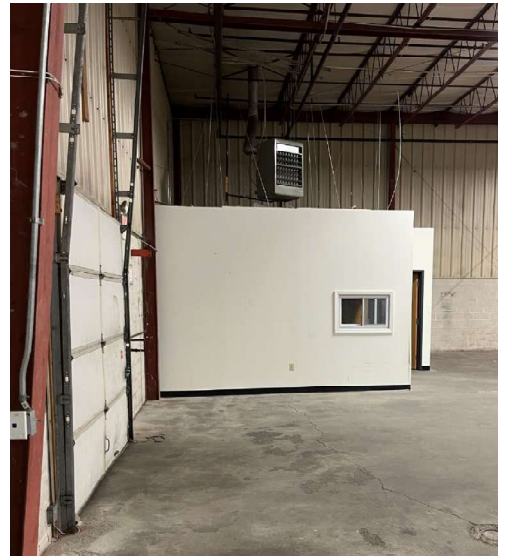



# **We're Ready to Help You Build the Perfect Environmental Room**

---

1-800-899-3774 | 835-207-7750

[Steve.Laret@dvmppower.com](mailto:Steve.Laret@dvmppower.com)

<https://thermmax.com/>

